

# SCREEN WINCH SYSTEM INSTALLATION MANUAL

## FOR SCREENS UP TO 300 cm. of width

Before installing the screen winch system, please read the following instructions carefully:



- *The screen winch system must be used INDOORS ONLY.*
- *The screen winch system must be installed by qualified personnel only.*
- *AFTER UNPACKING THE SCREEN WINCH TAKE CARE THAT WHEN RELEASING THE PACKAGING FOAM FROM THE TRACTION STEEL CABLES, YOU HAVE TO HANG EITHER THE SCREEN OR A MINIMUM WEIGHT OF 5 KG. TO EACH STEEL CABLE. THIS IN ORDER TO PREVENT THAT THE STEEL CABLES RAVEL UP INSIDE THE WINCH HOUSING.*
- *NEVER CONNECT MORE THAN ONE MOTOR TO THE SAME SWITCHER. Use the supplied switcher only.*
- *NEVER CONNECT SCREEN WINCH MOTOR AND SCREEN MOTOR TO THE SAME SWITCHER.*
- *IN CASE OF MAINTANANCE, UNPLUG THE POWER SUPPLY.*
- *In case the screen winch is controlled via relais, take care that the control system is programmed so there is no tension on the relais for at least 1 sec. during switching between rolling up and rolling down operations and viceversa.*
- *It is forbidden to operate screen winch system and projection screen simultaneously (risk of permanent motor damage). You have to activate first the winch unit and after it has reached the bottom end stop, you can roll down the projection screen.*
- *In case of need to activate both motors simultaneously, please install the multiple control interface set between switcher and winch and between switcher and projection screen.*
- *Incorrect use of the screen winch system, including exceeding the maximum lifting weight of 36 kg., would be dangerous and invalidates the warranty.*
- *Half-yearly the screen winch system has to be checked. Please see check register on page 7 of this document.*
- *It is forbidden to stay under the screen winch system.*
- *For any repairing, please contact directly the dealer you purchased the unit from.*

The manufacturer and his agents do not take responsibility for any damage to property or personal injury if the winch is installed/used outside of recommended specifications.



This product uses a 230 V AC motor. DO NOT attempt to carry out repairs to the motor, there are no user serviceable parts.

Incorrect servicing could lead to risk of electric shock. For any repairing, please contact directly the dealer you purchased the unit from. In the event of a fault please contact the dealer /supplier. Warranty is 24 months Return To Base.

The screen winch system is  certified.

### TECHNICAL DATAS

Motor: Power 50 Nm  
Speed 11 rpm  
Consumption 255 W

Roll down speed: 19 sec. per metre

Net weight of the Screen Winch System: kg. 40

Maximum roll down stroke: 7 mt.

Maximum load that can be hung to the screen winch system: kg. 36

## SUPPLIED EQUIPMENT LIST:

When you open the packaging, please **CHECK** that it contains **ALL** the components below:

1. 1x SCREEN WINCH SYSTEM
2. 1x UP/DOWN SWITCHER
3. 1x CABLE COILER
4. 3x FIXING BRACKETS FOR FIXING THE SCREEN WINCH TO THE CEILING
5. 2x MOUNTING PLATES
6. 1x "L" SHAPE BRACKET FOR MOUNTING THE CONNECTOR BOX
7. 1x CONNECTOR BOX
8. 1x INSTALLATION MANUAL

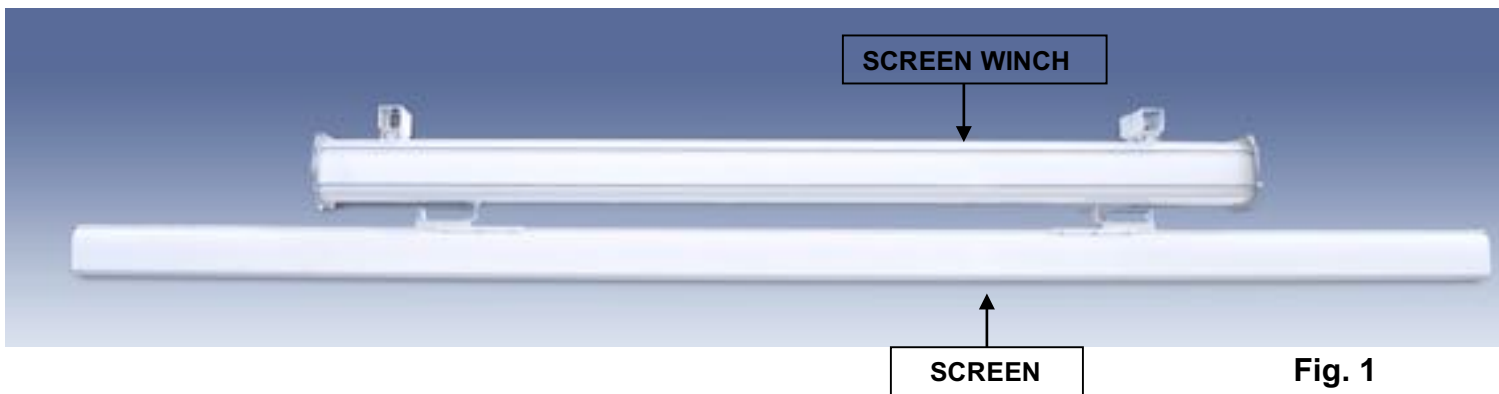

Fig. 1

This Screen Winch System is made to lift the screens models COMPACT – MAJOR – ELLIPSE and E-LITE manufactured by Euroscreen SRL.

In order to mount this winch system and the projection screen, please read **carefully** the following instructions:

1. First of all fix to the ceiling the 3 brackets for the screen winch, taking care that these 3 brackets are perfectly aligned and also mounted horizontally. From the central bracket, the left and right brackets have to be mounted at 98 cm distance from the central bracket. (see Fig. 1). Each bracket has to be mounted to the ceiling like showed in Fig. 2 with 4 suitable screws or bolts (**fixings are not supplied**).

2. Fix the screen winch (seen from the front with the power cable at the right side of the housing) at the brackets as shown in Fig. 3. First move the clamps close to the winch housing and tighten the nuts inside the bracket as shown in Fig. 3. Now in order to secure the clamps, tighten the 2 front screws of the bracket like shown in Fig. 4.



Fig. 2



Fig. 3

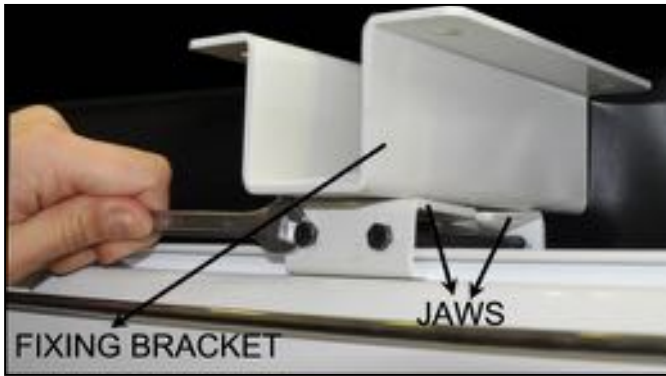
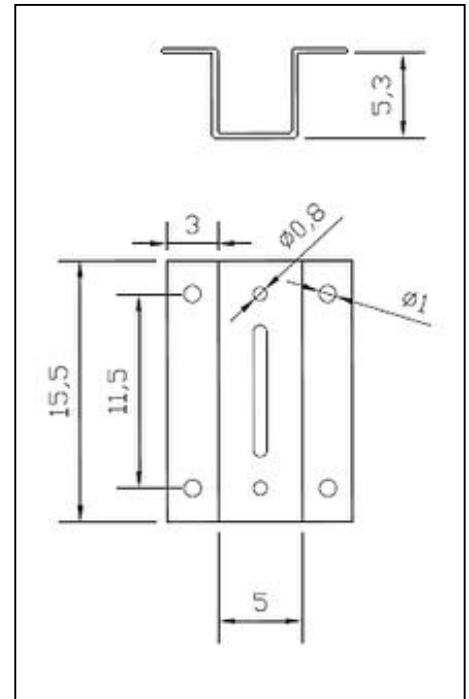
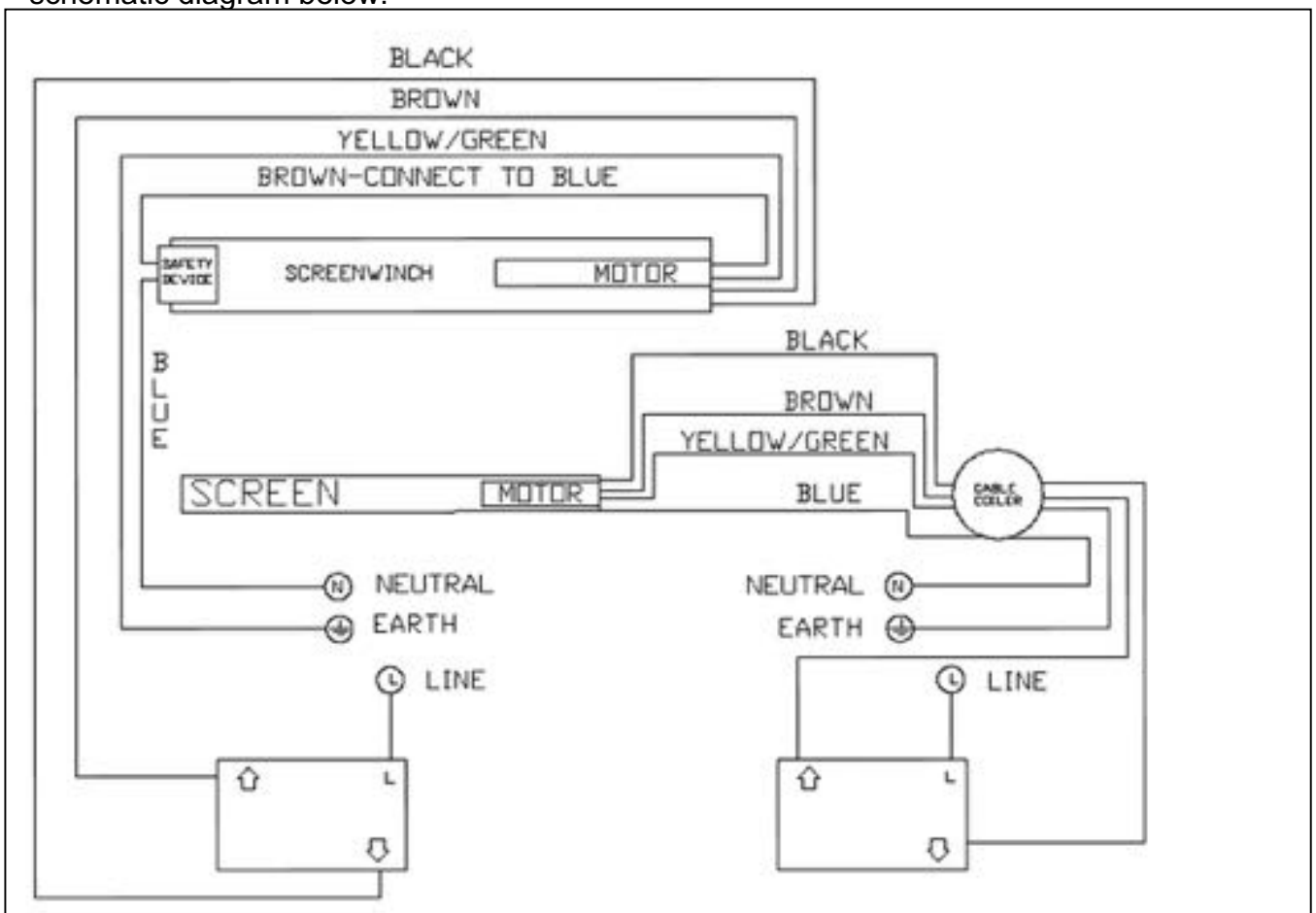

Fig. 4



**Drawing of the bracket** for fixing the screen winch system to the ceiling

3. Now connect the power cable of the screen winch to the 220V mains. The winch is equipped with a safety device that will prevent the roll down of the winch in case that the traction parts of the motor will fail. For the electrical connection of screen winch system, safety device and screen, see schematic diagram below.



4. Unpack the screen and make a little sign exactly in the middle of the screen housing. Now mount one mounting plate at 65 cm. right from the middle point with the eyebolt at the right side and mount the other mounting plate at 65 cm. left from the middle point with the eyebolt at the left side (see Fig. 5).

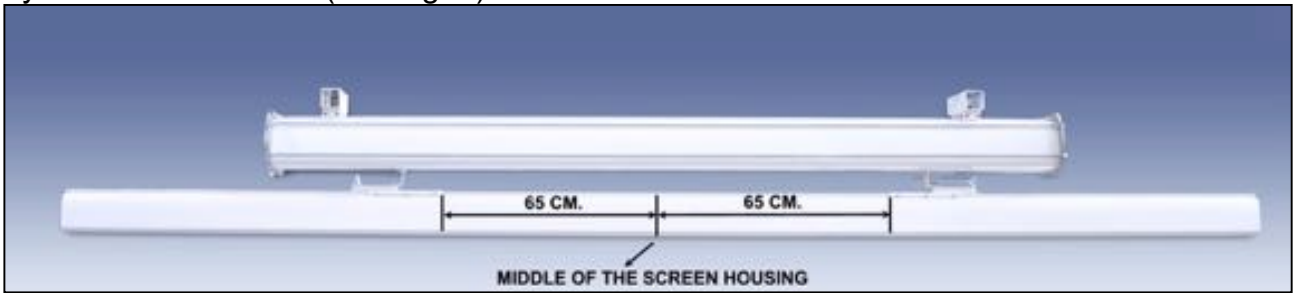

**Fig. 5**

5. With the winch completely rolled up, bring the screen housing under the screen winch and fix the right and left steel cables by the adjustment bolts through the eyebolts at the L-form brackets (see Fig. 6).

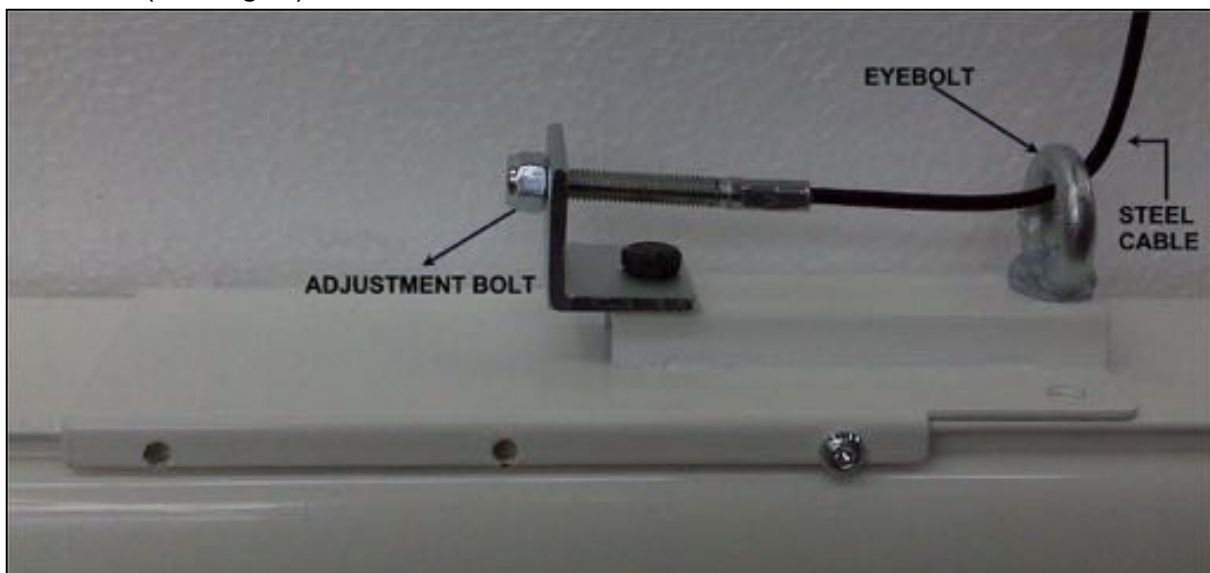

**Fig. 6**

6. Now check that the screen cabinet is perfectly levelled. In case not, please correct it by adjusting the bolt on the “L” form brackets.

7. To connect the mains 220V to the screen, you have to use the cable coiler that is included in the packaging. Mount the cable coiler (see Fig. 6B) to the ceiling behind the screen winch housing at the right side, using suitable screw anchors (**fixings are not supplied**).



**Fig. 6B – CABLE COILER**

8. Fix the connector box to the “L” shape bracket using the supplied screw and then, fix on the screen housing the “L” shape bracket as indicated in Fig. 7. Now fit the output power cable of the screen winch through the bracket and fix it with a wire clamp as shown in Fig.7 in order that it remains fixed when the screen housing moves up and down. Connect, inside the connector box, the end of output power cable of the cable coiler to the power cable that comes out of the screen housing (Fig. 8). At this step, you have to connect to the incoming power cable of the cable coiler fixed at the ceiling a plug and connect it with a switcher to the mains up in the ceiling.



**Fig. 7**



**Fig. 8**

**WARNING:** Once you have installed the product, when you switch on the Screen Winch System you will hear a rhythmical ticking which means that the safety device is working properly.

## END STOP ADJUSTMENT OF THE SCREEN WINCH



**WARNING: THE END STOP ADJUSTMENT HAS TO BE DONE CAREFULLY, OTHERWISE THE SCREEN WINCH CAN BE DAMAGED PERMANENTLY.**

**DO NOT SET THE BOTTOM END STOP LOWER THAN 7 MT.**

**In case the bottom end stop is set lower than 7 mt. DANGER OF FALLING DOWN OF THE PROJECTION SCREEN HOUSING.**

In case, after installation, the end stops of the Screen Winch System need to be changed, please, proceed as follows:

- at the right side of the Screen Winch System, in the lower part of the cabinet you will find two round holes: the first hole, which is the closest to the steel cables, will allow you to enter with a 4 mm. Allen key. You can adjust the **BOTTOM END STOP** as follows (see Fig. 9 and Fig. 10):

- Turn clockwise to increase down limit
- Turn counter clockwise to raise bottom stop point

The other hole, allows you to adjust the **UPPER END STOP**:

- Turn counter clockwise to lower the upper stop point

**DO NOT RAISE UP LIMIT, OTHERWISE THE SCREEN WINCH SYSTEM CAN BE DAMAGED PERMANENTLY.**



Fig. 9



Fig. 10

**WARNING: do not change the end stops of the projection screen, otherwise you will invalidate the warranty on the screen.**



## SCREEN WINCH SYSTEM - CHECK REGISTER

**SCREEN WINCH SYSTEM PURCHASE DATE:**

HALF-YEARLY CHECK DATE	YEARLY CHECK DATE	CHECK RESULT (POSITIVE - NEGATIVE)	NOTES

<b>HALF-YEARLY CHECK</b>	<p>Check if rolling up and rolling down is working properly, without frictions or decelerations.</p> <p>Check that if you can hear the ticking noise of the safety brake is present.</p> <p>Check with the end user that projector lift and projection screen (if this is the configuration) operate in different times (not at the same time) .</p>
<b>YEARLY CHECK</b>	<p>Check steel cables covered by black PVC – no steel wires have to be visible outside the black PVC scabbard.</p> <p>Check of the ceiling fixing brackets of the screen winch system</p> <p>Check that the end stops are set properly, so that in the rolled down position (screen winch system completely open) it remains at least 3 turns of steel wire onto the roller tube.</p> <p>Check that bolts on the bottom ends of the steel cables are tightly fixed.</p> <p>Check if rolling up and rolling down is working properly, without frictions or decelerations.</p> <p>Check that if you can hear the ticking noise of the safety brake is present.</p> <p>Check with the end user that projector lift and projection screen (if this is the configuration) operate in different times (not at the same time) .</p>